



# VXE DN 10÷50

PVC-U

Easyfit 2-way ball valve



# VXE DN 10÷50

FIP and Giugiaro Design designed and developed VXE Easyfit, the innovative True Union ball with union nut tightening control that permits simple and safe installation for reliable service in time. This valve is also equipped with the customisable Labelling System.



## EASYFIT 2-WAY BALL VALVE

- **Patented Easyfit system:** innovative mechanism based on the principle of the bevel gear pair that controls valve union nut rotation during installation
- Connection system for solvent weld and threaded joints
- **Valve material compatibility** (PVC-C) and elastomer **seal elements** (EPDM or FKM), with water, drinking water and other food substances as per **current regulations**
- Easy radial disassembly allowing quick replacement of O-rings and ball seats without any need for tools
- **PN16 True Union valve body** made for PVC-C injection moulding and European Directive 2014/68/EU (PED) compliant for pressurised equipment. ISO 9393 compliant test requirements
- Fully interchangeable with previous VX Ergo series models
- Option of disassembling downstream pipes with the valve in the closed position
- Floating **full bore ball** with high surface finish made in CNC work stations to achieve precise dimensional tolerance and high surface finish

Technical specifications	
<b>Construction</b>	Easyfit 2-way True Union ball valve with locked carrier
<b>Size range</b>	DN 10 ÷ 50
<b>Nominal pressure</b>	PN 16 with water at 20 °C
<b>Temperature range</b>	0 °C ÷ 60 °C
<b>Coupling standards</b>	<p><b>Solvent welding:</b> EN ISO 1452, EN ISO 15493, BS 4346-1, DIN 8063, NF T54-028, ASTM D 2467, JIS K 6743. Pipe coupling capacity according to EN ISO 1452, EN ISO 15493, DIN 8062, NF T54-016, ASTM D 1785, JIS K 6741</p> <p><b>Thread:</b> ISO 228-1, DIN 2999, ASTM D 2467 JIS B 0203.</p>
<b>Reference standards</b>	<p><b>Construction criteria:</b> EN ISO 16135, EN ISO 1452, EN ISO 15493</p> <p><b>Test methods and requirements:</b> ISO 9393</p> <p><b>Installation criteria:</b> DVS 2204, DVS 2221, UNI 11242</p> <p><b>Actuator couplings:</b> ISO 5211</p>
<b>Valve material</b>	PVC-U
<b>Seal material</b>	EPDM, FKM (standard size O-Ring); PTFE (ball seats)
<b>Control options</b>	Manual control

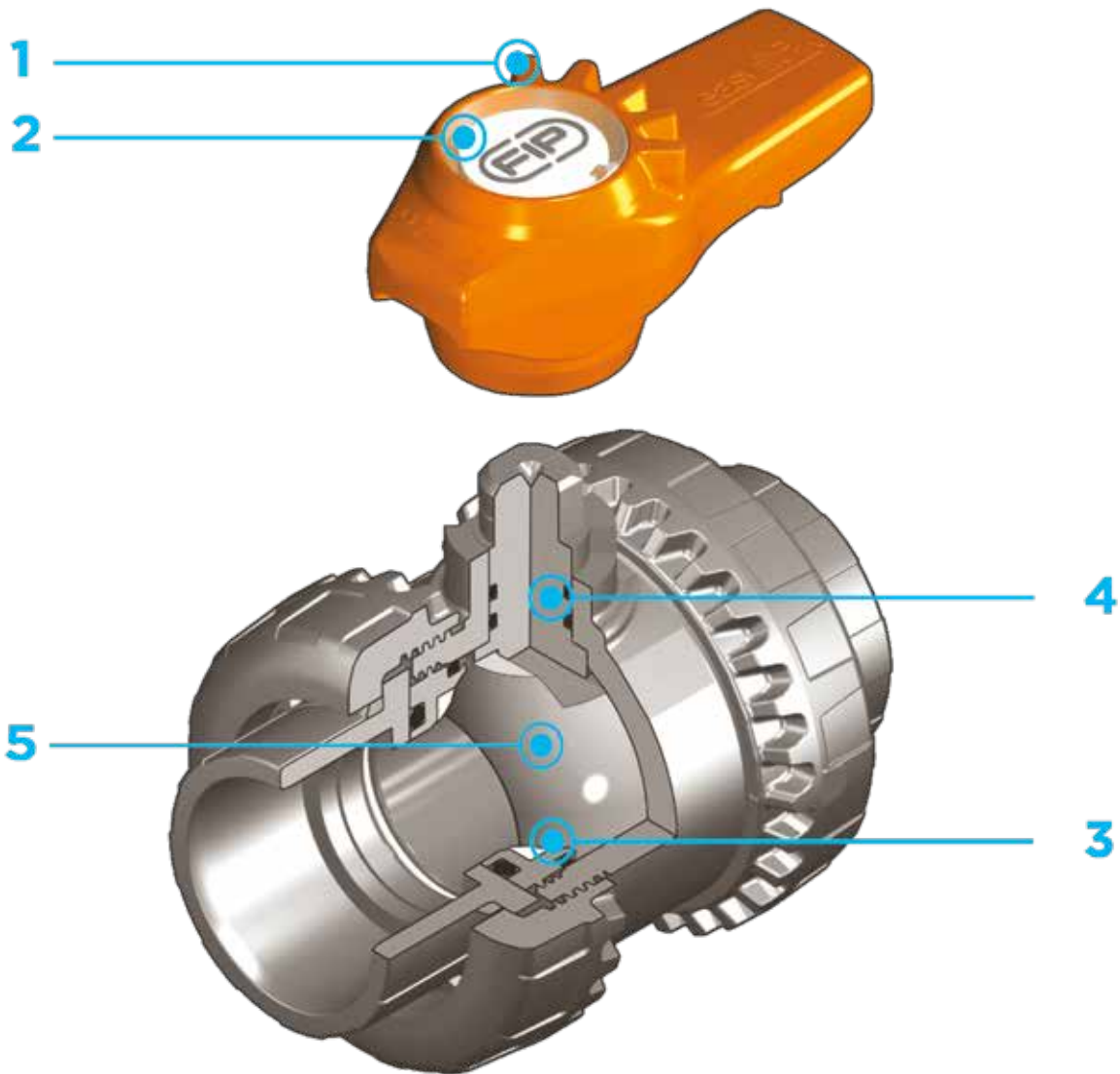

**1** Two position **Easyfit ergonomic multifunctional handle with union nut tightening control** which can be used to **adjust ball seat carriers**. Handle use is especially indicated for **maintenance** work where **space is limited** and hard to access

**2** **Customisable Labelling System: built-in LCE module** on the handle made up of a transparent

protection plug and customisable tag holder with LSE set (available as accessory). The customisation potential lets you **identify the valve on the system** according to specific needs

**3** **The PTFE ball seat system with locked carrier** adjustable via Easyfit multifunctional handle or Easytorque adjustment kit (available as an accessory)

**4** High surface finish **valve stem with double O-Ring**, produced in CNC work stations to achieve precise dimensional tolerance and increased reliability

**5** Machined high surface finish ball that guarantees a smooth operation and increased reliability

# TECHNICAL DATA

## PRESSURE VARIATION ACCORDING TO TEMPERATURE

For water and harmless fluids to which the material is classified as CHEMICALLY RESISTANT. In other cases, a reduction of the nominal PN pressure is required (25 years with safety factor).



## PRESSURE DROP GRAPH

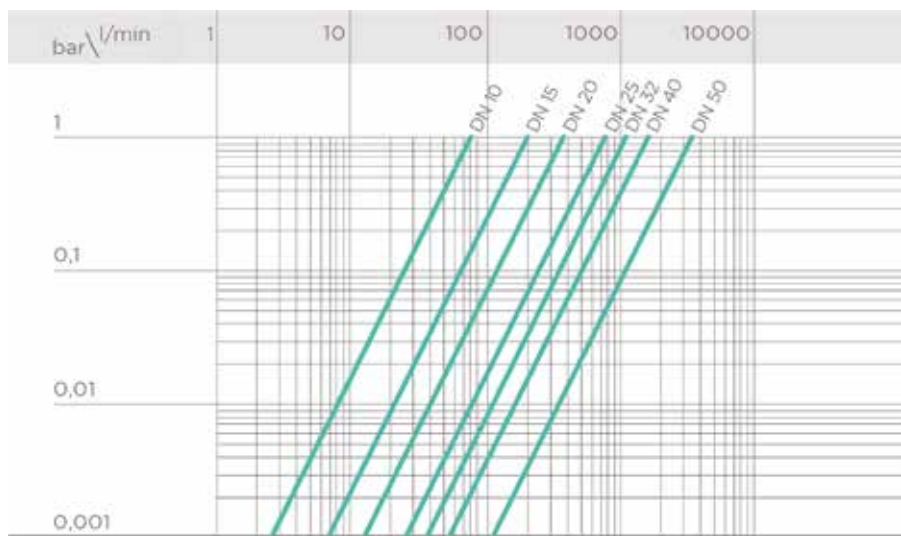

## K<sub>v</sub>100 FLOW COEFFICIENT

The K<sub>v</sub>100 flow coefficient is the Q flow rate of litres per minute of water at a temperature of 20°C that will generate Δp= 1 bar pressure drop at a certain valve position. The K<sub>v</sub>100 values shown in the table are calculated with the valve completely open.

DN	10	15	20	25	32	40	50
K <sub>v</sub> 100 l/min	80	200	385	770	1110	1750	3400

The information in this leaflet is provided in good faith. No liability will be accepted concerning technical data that is not directly covered by recognised international standards. FIP reserves the right to carry out any modification. Products must be installed and maintained by qualified personnel.

# DIMENSIONS

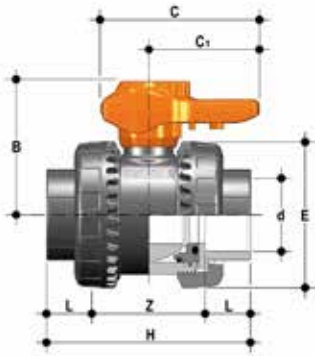

## VXEIV

Easyfit 2-way ball valve with female ends for solvent welding, metric series

d	DN	PN	B	C	C <sub>1</sub>	E	H	L	Z	g	EPDM code	FKM code
16	10	16	49	64	44	54	82	14	50	180	VXEIV016E	VXEIV016F
20	15	16	49	64	44	54	82	16	50	175	VXEIV020E	VXEIV020F
25	20	16	62	78	55	63	91	19	53	260	VXEIV025E	VXEIV025F
32	25	16	71	87	60	72	103	22	59	365	VXEIV032E	VXEIV032F
40	32	16	82	102	72	85	120	26	68	565	VXEIV040E	VXEIV040F
50	40	16	92	109	76	100	139	31	77	795	VXEIV050E	VXEIV050F
63	50	16	110	133	94	118	174	38	98	1325	VXEIV063E	VXEIV063F

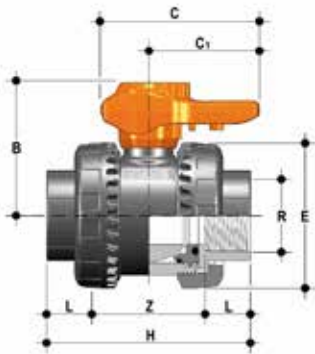

## VXEFV

Easyfit 2-way ball valve with BSP threaded female ends

R	DN	PN	B	C	C <sub>1</sub>	E	H	L	Z	g	EPDM code	FKM code
3/8"	10	16	49	64	44	54	82	11,4	59,2	180	VXEFV038E	VXEFV038F
1/2"	15	16	49	64	44	54	90	15	60	175	VXEFV012E	VXEFV012F
3/4"	20	16	62	78	55	63	93	16,3	60,4	260	VXEFV034E	VXEFV034F
1"	25	16	71	87	60	72	110	19,1	71,8	365	VXEFV100E	VXEFV100F
1" 1/4	32	16	82	102	72	85	127	21,4	84,2	565	VXEFV114E	VXEFV114F
1" 1/2	40	16	92	109	76	100	131	21,4	88,2	795	VXEFV112E	VXEFV112F
2"	50	16	110	133	94	118	161	25,7	109,6	1325	VXEFV200E	VXEFV200F



## VXELV

Easyfit 2-way ball valve with female ends for solvent welding, BS series

d	DN	PN	B	C	C <sub>1</sub>	E	H	L	Z	g	EPDM code	FKM code
3/8"	10	16	49	64	44	54	78	14,5	49	180	VXELV038E	VXELV038F
1/2"	15	16	49	64	44	54	82	16,5	49	175	VXELV012E	VXELV012F
3/4"	20	16	62	78	55	63	91	19	53	260	VXELV034E	VXELV034F
1"	25	16	71	87	60	72	103	22,5	58	365	VXELV100E	VXELV100F
1 1/4"	32	16	82	102	72	85	120	26	68	565	VXELV114E	VXELV114F
1 1/2"	40	16	92	109	76	100	139	30	79	795	VXELV112E	VXELV112F
2"	50	16	110	133	94	118	174	36	102	1325	VXELV200E	VXELV200F

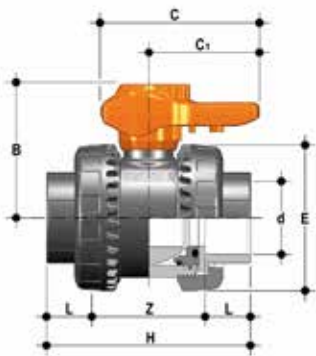

## VXEAV

Easyfit 2-way ball valve with female ends for solvent welding, ASTM series

d	DN	PN	B	C	C <sub>1</sub>	E	H	L	Z	g	EPDM code	FKM code
1/2"	15	16	49	64	44	54	96	22,5	51	175	VXEAV012E	VXEAV012F
3/4"	20	16	62	78	55	63	105	25,5	54	260	VXEAV034E	VXEAV034F
1"	25	16	71	87	60	72	117	28,7	59,5	365	VXEAV100E	VXEAV100F
1 1/4"	32	16	82	102	72	85	136	32	72	565	VXEAV114E	VXEAV114F
1 1/2"	40	16	92	109	76	100	147	35	77	795	VXEAV112E	VXEAV112F
2"	50	16	110	133	94	118	174	38,2	97,6	1325	VXEAV200E	VXEAV200F

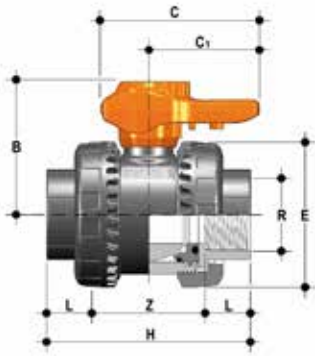

## VXENV

Easyfit 2-way ball valve with female ends, NPT thread

R	DN	PN	B	C	C <sub>1</sub>	E	H	L	Z	g	EPDM code	FKM code
3/8"	10	16	49	64	44	54	82	13,7	54,6	180	VXENV038E	VXENV038F
1/2"	15	16	49	64	44	54	90	17,8	54,4	175	VXENV012E	VXENV012F
3/4"	20	16	62	78	55	63	93	18	57	260	VXENV034E	VXENV034F
1"	25	16	71	87	60	72	110	22,6	64,8	365	VXENV100E	VXENV100F
1" 1/4	32	16	82	102	72	85	127	25,1	76,8	565	VXENV114E	VXENV114F
1" 1/2	40	16	92	109	76	100	131	24,7	81,6	795	VXENV112E	VXENV112F
2"	50	16	110	133	94	118	161	29,6	101,8	1325	VXENV200E	VXENV200F

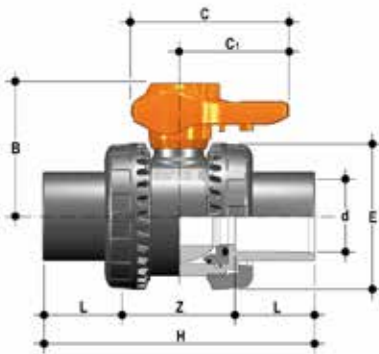

## VXEJV

Easyfit 2-way ball valve with female ends for solvent welding, JIS series

d	DN	PN	B	C	C <sub>1</sub>	E	H	L	Z	g	EPDM code	FKM code
1/2"	15	16	49	64	44	54	110	30	50	195	VXEJV012E	VXEJV012F
3/4"	20	16	62	78	55	63	123	35	53	285	VXEJV034E	VXEJV034F
1"	25	16	71	87	60	72	139	40	59	395	VXEJV100E	VXEJV100F
1" 1/4	32	16	82	102	72	85	156	44	68	600	VXEJV114E	VXEJV114F
1" 1/2	40	16	92	109	76	100	187	55	77	835	VXEJV112E	VXEJV112F
2"	50	16	110	133	94	118	228	63	102	1375	VXEJV200E	VXEJV200F

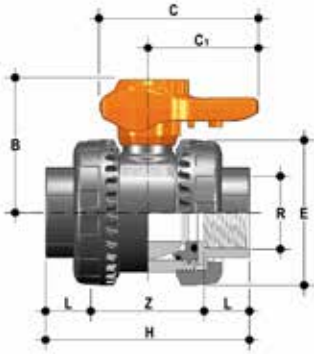

## VXEGV

Easyfit 2-way valve with female ends, JIS thread

R	DN	PN	B	C	C <sub>1</sub>	E	H	L	Z	g	EPDM code	FKM code
1/2"	15	16	49	64	44	54	82	16	50	175	VXEGV012E	VXEGV012F
3/4"	20	16	62	78	55	63	91	19	53	260	VXEGV034E	VXEGV034F
1"	25	16	71	87	60	72	103	22	59	365	VXEGV100E	VXEGV100F
1" 1/4	32	16	82	102	72	85	120	25	70	565	VXEGV114E	VXEGV114F
1" 1/2	40	16	92	109	76	100	139	26	87	795	VXEGV112E	VXEGV112F
2"	50	16	110	133	94	118	174	31	112	1325	VXEGV200E	VXEGV200F

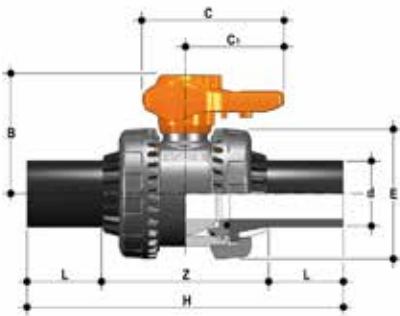

## VXEDEV

Easyfit 2-way ball valve with PE100 SDR 11 male end connectors for butt welding or electrofusion (CVDE)

d	DN	PN	B	C	C <sub>1</sub>	E	H	L	Z	g	EPDM code	FKM code
20	15	16	49	64	44	54	154	40,5	73	180	VXEDEV020E	VXEDEV020F
25	20	16	62	78	55	63	189	54	81	269	VXEDEV025E	VXEDEV025F
32	25	16	71	87	60	72	203	56	91	379	VXEDEV032E	VXEDEV032F
40	32	16	82	102	72	85	221	56	109	591	VXEDEV040E	VXEDEV040F
50	40	16	92	109	76	100	246	60,5	125	851	VXEDEV050E	VXEDEV050F
63	50	16	110	133	94	118	276	65,5	145	1407	VXEDEV063E	VXEDEV063F



# ACCESSORIES

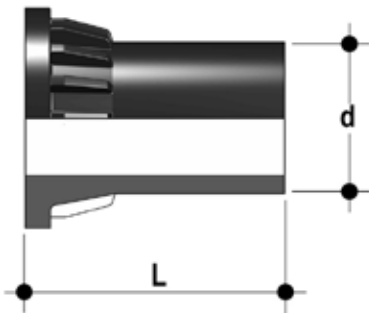

## CVDE

Long spigot PE100 end connectors for joints with electrofusion fittings or for butt welding

d	DN	PN	L	SDR	Code
20	15	16	55	11	CVDE11020
25	20	16	70	11	CVDE11025
32	25	16	74	11	CVDE11032
40	32	16	78	11	CVDE11040
50	40	16	84	11	CVDE11050
63	50	16	91	11	CVDE11063



## EASYTORQUE KIT

Kit for union nut tightening adjustment and ball seat carrier for Easyfit DN 10÷50 valves.

d	DN	Union nut tightening torque*	Seat carrier tightening torque*	Code
3/8"-1/2"	10-15	5 N m - 3,69 Lbf ft	3 N m - 2,21 Lbf ft	KET01
3/4"	20	5 N m - 3,69 Lbf ft	3 N m - 2,21 Lbf ft	KET01
1"	25	6 N m - 4,43 Lbf ft	4 N m - 2,95 Lbf ft	KET01
1" 1/4	32	7 N m - 5,16 Lbf ft	4 N m - 2,95 Lbf ft	KET01
1" 1/2	40	8 N m - 5,90 Lbf ft	5 N m - 3,69 Lbf ft	KET01
2"	50	10 N m - 7,38 Lbf ft	6 N m - 4,43 Lbf ft	KET01

\*calculated in ideal installation conditions



## LCE

Transparent protection plug with tag holder

d	DN	VEE code
16	10	LCE020
20	15	LCE020
25	20	LCE025
32	25	LCE032
40	32	LCE040
50	40	LCE050
63	50	LCE063



## LSE

Customisation and label printing set for Easyfit handle made up of pre-cut adhesive sheets and software for guided label creation.

d	DN	VEE-VXE code
16	10	LSE020
20	15	LSE020
25	20	LSE025
32	25	LSE032
40	32	LSE040
50	40	LSE050
63	50	LSE063

# CUSTOMISATION

Fig. 1



Fig. 2



Fig. 3

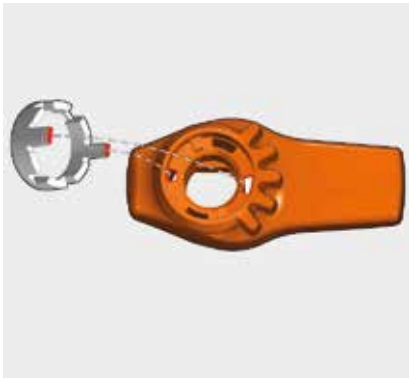

The VXE DN 10÷50 Easyfit valve is equipped with the customisable Labelling System.

This system lets you create special labels to insert in the handle. This makes it extremely easy to apply company logos, identification serial numbers or service indications such as, for example, the valve function in the system, the transported fluid, but also specific information for customer service, such as the customer name or installation date or location on the valves.

The specific LCE module is a standard supply and is made up of a rigid transparent water-resistant PVC plug (A) and white tag holder (B) made of the same material, one side of which bears the FIP logo (fig. 1).

The holder, inserted in the plug, can be removed and, once overturned, used for customisation by applying labels printed with the software supplied with the LSE set.

Proceed as follows to apply the label on the valve:

- 1) Extract the handle from the valve body and extract the transparent plug.
- 2) Extract the tag holder from the transparent plug (fig. 2).
- 3) Apply the adhesive label on the tag holder to align the profiles matching the tab position.
- 4) Re-insert the tag holder in the transparent plug so that the label is protected from the elements.
- 5) Apply the transparent plug on the handle matching the two fittings (one narrow and one wide) with their housings (fig. 3).

# COMPONENTS

## EXPLODED VIEW

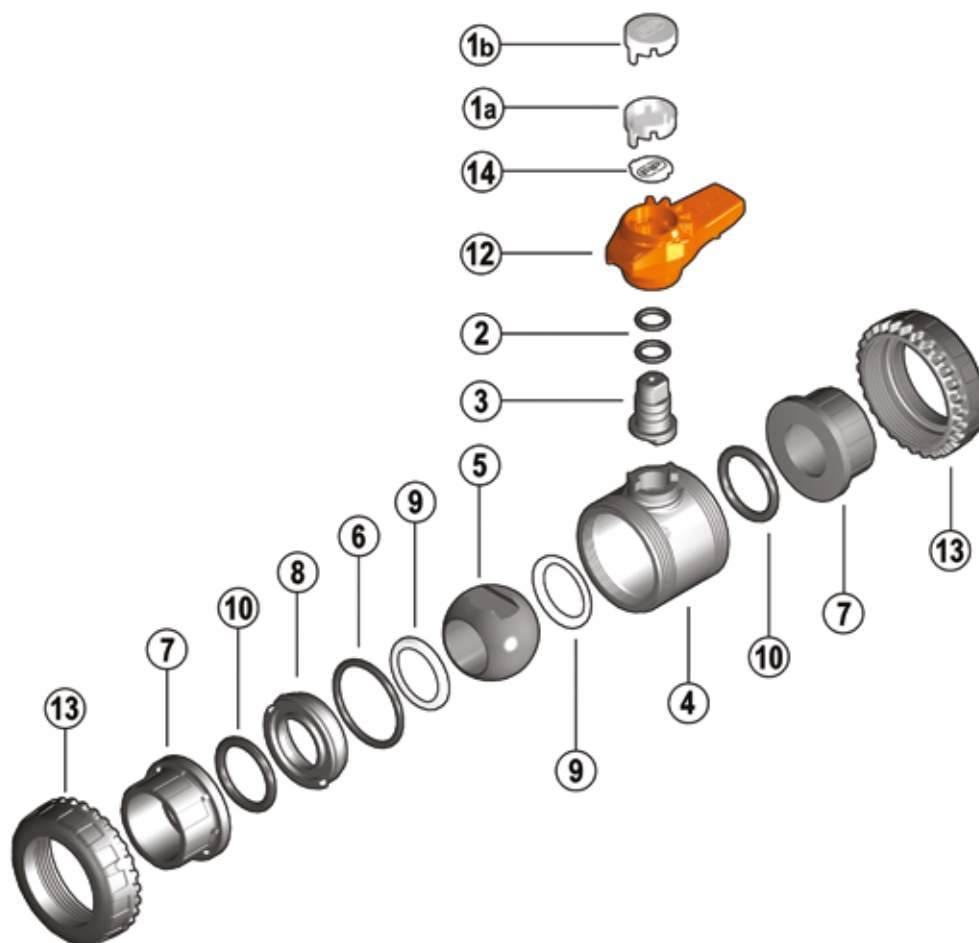

**1a** Transparent protection plug (PVC - 1)

**2** Stem O-rings (EPDM-FKM - 2)\*

**3** Stem (PVC-U - 1)

**4** Body (PVC-U - 1)

**5** Ball (PVC-U - 1)

**6** Radial seal O-Ring (EPDM-FKM - 1)\*

**7** End connector (PVC-U - 2)

**8** Ball seat carrier (PVC-U - 1)

**9** Ball seat (PTFE - 2)\*

**10** Socket seal O-Ring (EPDM-FKM - 2)\*

**12** Handle (HIPVC - 1)

**13** Union nut (PVC-U - 2)

**14** Tag holder (PVC-U - 1)

\* Spare parts

The component material and quantity supplied are indicated in the parentheses.

## DISASSEMBLY

- 1) Isolate the valve from the line (release the pressure and empty the pipeline).
- 2) Fully unscrew the union nuts (13) from the valve body and slide the body out sideways (fig. 4-5). To do this, we recommend you use the Easyfit handle as a tool (fig. 8-9)
- 3) Before dismounting, hold the valve in a vertical position and open it 45° to drain any liquid that might remain.
- 4) After closing the valve, remove the handle (12) (fig. 6) and insert the two protrusions in the lower side in the two apertures and in the carrier passage bore (8) extracting it by turning counter-clockwise (fig. 7).
- 5) Press on the ball from the side opposite the "REGULAR" label, being sure not to scratch it, until the ball seat exits (9), then extract the ball (5).
- 6) Press the stem (3) inwards until it exits the body.
- 7) Remove the O-Rings (2, 6, 10) and ball seats (9) extracting them from their seats, as illustrated in the exploded view.

## ASSEMBLY

- 1) All the O-Rings (2, 6, 10) must be inserted in their grooves as shown in the exploded view.
- 2) Insert the stem (3) from inside the body (4).
- 3) Place the ball seats (9) in the housings in the body (4) and in the carrier (8).
- 4) Insert the ball (5) rotating it to the closed position.
- 5) Screw the carrier (8) into the body and tighten up in the clockwise direction using the handle (12) to limit stop.
- 6) Position the valve between the end connectors (7) and tighten the union nuts (13) clockwise using the Easyfit multifunctional handle, being sure the socket seal O-Rings (10) do not exit the seats.
- 7) Position the handle (12) on the stem (3).



**Note:** during assembly operations, it is advisable to lubricate the rubber seals. Mineral oils are not recommended for this task as they react aggressively with EPDM rubber.

Fig. 4



Fig. 5



Fig. 6



Fig. 7



# INSTALLATION

Before proceeding with installation, please follow these instructions carefully:

- 1) Check that the pipes to be connected to the valve are aligned in order to avoid mechanical stress on the threaded joints.
- 2) Unscrew the union nuts from the valve body (4) and slide them onto the pipe.
- 3) Solvent weld or screw the end connectors (7) onto the pipe segments.
- 4) Position the valve body between the end connectors (fig. 5). Warning: if a high pressure test is required, always position the body with the "REGULAR" label upstream from the fluid direction.
- 5) Fit the union nuts on the valve body and manually tighten clockwise until they become hard to turn; do not use wrenches or other tools that can damage the union nut surfaces.
- 6) Extract the handle (12) from the valve body and extract the transparent plug (1a).
- 7) Overturn the handle and insert it on the valve stem matching the handle teeth (A) with the union nut teeth (B) (fig. 8-9).
- 8) Turn the handle counter-clockwise to fully tighten the union nut. The rotation directions to tighten (TIGHTEN) and loosen (UNTIGHTEN) the union nuts are indicated on the handle (fig. 10). Generally, if pipes are not offset, one turn is sufficient for correct tightening.
- 9) Repeat point 7 for the other union nut. Note: A small force applied on the handle develops a torque much higher than manual tightening. You can also, using the Easytorque kit (fig. 11), supplied as an accessory, tighten union nuts using a torque wrench to quantify the force and thus monitor the stress applied to the thermoplastic threads according to the installation indications in the instructions enclosed with the kit.
- 10) Apply the plug (1a) on the handle (12) matching the two fittings (one narrow and one wide) with the relevant housings on the handle (fig. 3).
- 11) Install the handle (12) on the stem (3) again.
- 12) If necessary, support the pipe with FIP pipe clip model ZIKM and DSM distance plates.

## WARNINGS

If volatile liquid such as Hydrogen Peroxide (H<sub>2</sub>O<sub>2</sub>) or Sodium Hypochlorite (NaClO) is used, for safety reasons we recommend you contact the service centre. These liquids, upon vaporising, could create hazardous over pressures in the area between the body and ball.

Do not use compressed air or other gases to test thermoplastic lines.

Always avoid sudden closing manoeuvres and protect the valve from accidental manoeuvres.

Fig. 8



Fig. 9



Fig. 10



Fig. 11

