

Mark 501/502 Series

High Flow Back Pressure Regulators

The Mark 501 and 502 meet higher capacity requirements than standard back pressure regulators. The High Flow Mark 501 has Cv's as high as 50 (43Kv) and the Super High Flow Mark 502 has Cv's up to 70 (60,2 Kv). Each valve is standard with Jordan's Sliding Gate Seats, which helps to reduce the build-up commonly associated with high flow back pressure regulators.

Jordan's unique self-operated sliding gate back pressure regulator offers:

Shorter stroke than a globe or plug-style valve

- Faster response
- Smaller and lighter weight than globe-style valves
- Less build-up

Straight through flow

- Less turbulence, erosion and noise
- Improved rangeability
- Longer seat life

Ease of maintenance

- Interchangeable seats and Cv's
- Fewer spare parts
- Self-cleaning seats
- No gaskets or o-rings

SPECIFICATIONS

Sizes: 1-1/2" & 2" (DN40 & DN50)

End Connections:

- Threaded (FNPT, BSPT, BSPP)
- ANSI Flanges (150#, 300#)
- DIN Flanges (PN10/16, PN25/40)

Body Materials: Ductile Iron, Bronze, Carbon Steel (A216 WCB), Stainless Steel (A351/CF8M)

Trim Materials:

- 303SST — Standard on Ductile Iron, Bronze, Carbon Steel valves
- 316SST — Standard on Stainless Steel Valves
- Monel, Hastelloy and other Alloys available
-

Seat Materials:

- Jorcote on SST — Standard



Diaphragm Materials:

- Stainless Steel — standard
- Buna-N — optional
- Jorlon — optional
- Viton — optional

Service: Steam, water, oil, gas, air and chemicals

Shutoff: ANSI Class IV

Reduced Pressure Control Ranges: Select a range to match your setpoint. For optimal performance, your setpoint should fall in the upper portion of the selected range.

Model	Size (DN)	Spring Ranges	
		PSI	BAR
501 & 502	1-1/2" - 2" (DN40 - DN50)	0.5 - 4	0,03 - 0,28
		2 - 6	0,14 - 0,41
		4 - 13	0,28 - 0,90
		8 - 20	0,55 - 1,38
		15 - 80	1,03 - 5,52
		45 - 150	3,10 - 10,34

Cv Values & Maximum Differential Pressures

- Mark 501

Cv (Kv)	Size (DN)	Seat Material	Maximum ΔPSI (bar)
25 (21,5)	1-1/2" & 2" (DN40 & DN50)	Jorcote	150 (10,34)
30 (25,8)	1-1/2" & 2" (DN40 & DN50)	Jorcote	150 (10,34)
35 (30,1)	1-1/2" & 2" (DN40 & DN50)	Jorcote	150 (10,34)
45 (38,7)	1-1/2" (DN40)	Jorcote	150 (10,34)
50 (43,0)	2" (DN50)	Jorcote	150 (10,34)

- Mark 502

Cv (Kv)	Size (DN)	Seat Material	Maximum ΔPSI (bar)
65 (55,9)	1-1/2" (DN40)	Jorcote	150 (10,34)
70 (60,2)	2" (DN50)	Jorcote	150 (10,34)

DIMENSIONS — MK501/502

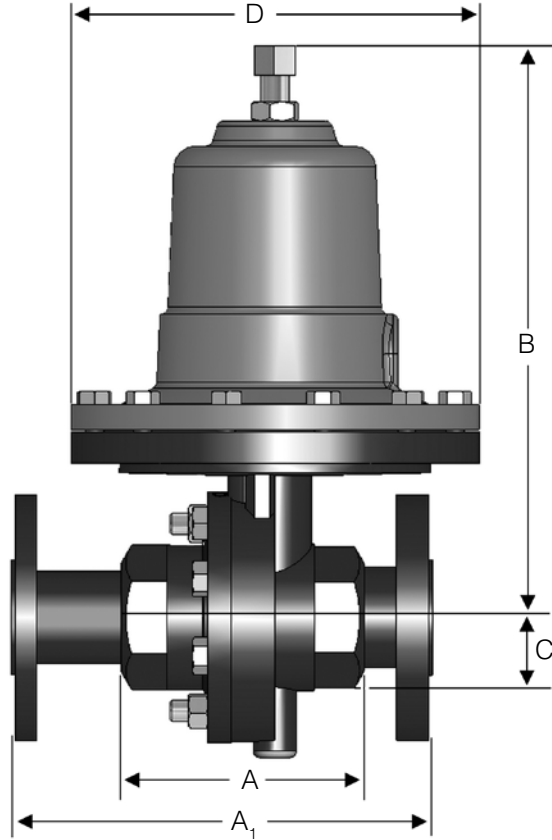

- Mark 501/502: Threaded & FSW Ends

Size	Material	Dimensions (inches)				Weight (lbs.)
		A	B	C	D	
1-1/2" - 2"	DI/BRZ	4.50	10.25	2.75	7.09	26
	CS/SS	5.50	11.00	2.75	7.09	35

- Mark 501/502: Threaded & FSW Ends, Metric

Size (DN)	Material	Dimensions (mm)				Weight (kg)
		A	B	C	D	
40 - 50	DI/BRZ	114	260	70	180	11,8
	CS/SS	140	279	70	180	15,9

- Mark 501/502, Flanged Ends

Size	ANSI Flange	Dimensions (inches)						Weight (lbs.)	
		A1		B		C	D	DI/BRZ	CS/SS
		DI/BRZ	CS/SS	DI/BRZ	CS/SS	All	All		
1-1/2"	150#	10.00*	10.00*	10.25	11.22	2.31	7.09	42	46
	300#	10.25*	10.25*	10.25	11.22	2.31	7.09	45	52
2"	150#	10.00	10.00	10.25	11.42	2.75	7.09	46	50
	300#	10.50	10.50	10.25	11.42	2.75	7.09	49	55

* Not IFE. Not ANSI Standard.

- Mark 501/502, Flanged Ends, Metric

Size (DN)	Flange PN	Dimensions (mm)						Weight (kg)	
		A1		B		C	D	DI/BRZ	CS/SS
		DI/BRZ	CS/SS	DI/BRZ	CS/SS	All	All		
40	10/16	254	254	279	285	58,7	180	19,1	20,9
	25/40	260	260	279	285	58,7	180	20,4	23,6
50	10/16	254	230	279	290	69,9	180	20,9	22,7
	25/40	267	230	279	290	69,9	180	22,2	24,9

ORDERING SCHEMATIC

1	—	2	—	3	/	4	5	6	7	8	9	10	11	12
----------	---	----------	---	----------	---	----------	----------	----------	----------	----------	----------	-----------	-----------	-----------

1	Model	
501	High Flow	
502	Super High Flow	

6	Seat Material	
V	303SS/Jorcote	
W	316SS/Jorcote	

2	Size	
	Inches (DN)	
150	1-1/2" (DN40)	
200	2" (DN50)	

7	Cv (Kv)	
A	25 (22)	
B	30 (26)	
V	35 (30)	
W	45 (39)	
C	50 (43)	
Y	65 (56)	
E	70 (60)	

3	Body Material	
DI	Ductile Iron	
BR	Bronze	
CS	Carbon Steel	
S6	Stainless Steel	

8	Range	
03	0.5 - 4 (0,03 - 0,28)	
06	2 - 6 (0,14 - 0,41)	
21	4 - 13 (0,28 - 0,90)	
31	8 - 20 (0,55 - 1,38)	
50	15 - 80 (1,03 - 5,52)	
95	45 - 150 (3,10 - 10,34)	

4	End Connections	
PT	NPT	
BT	BSPT	
I5	150# IFE CS or SST*	
F5	150# FE DI or BR	
I7	PN10 IFE CS or SST*	
F7	PN10 FE DI or BR	
I6	PN16 IFE CS or SST*	
F6	PN16 FE DI or BR	
BP	BSPP	
SW	FSW	
I3	300# IFE CS or SST*	
F3	300# FE DI or BR	
I8	PN25 IFE CS or SST*	
F8	PN25 FE DI or BR	
I4	PN40 IFE CS or SST*	
F4	PN40 FE DI or BR	

9	Diaphragm	
S6	316 SST	
VI	Viton	
BN	Buna-N	
JL	Jorlon	

10	Actuator	
MD	for Metal Diaphragm	
ED	for Elastomer Diaphragm	

* IFE (integral flanged end) for 2" only.
FE is threaded or weld flanges.

11	Double Bolting	
00	None	
ZZ	Non-Standard	

5	Trim	
S3	303SS	
S6	316SS	
I3	303SSF/IFE	
I6	316SSF/IFE	

12	Accessories	
0	None	
6	316 SS Bolting	
7	Hi-Temperature Bolting	
Z	Non-Standard	

